



TOYOSEIKI Kerbmaker Machine



TOYOSEIKI KERBMAKER MACHINE



MOULD SHAPES

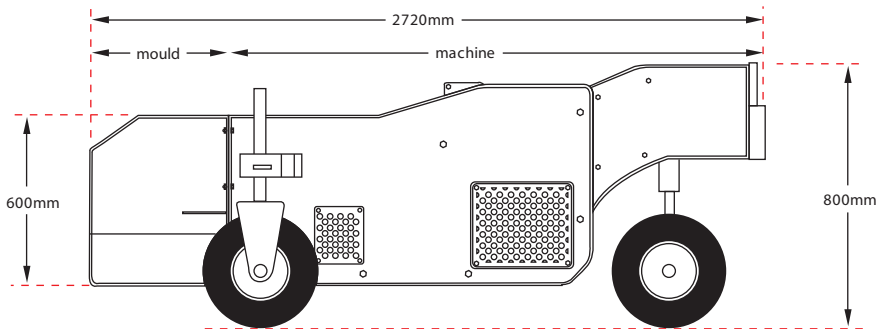
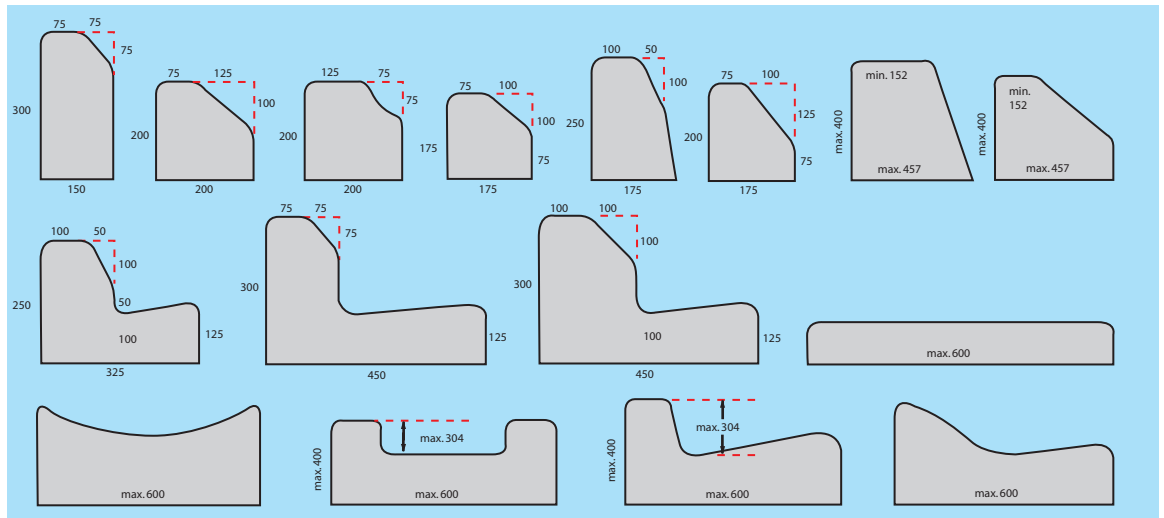

SPECIFICATION

- ENGINE : 18HP air cooled gasoline model with electric starter
- HYDRAULIC PUMP : Parker U.S.A
- REDUCTION BOX : Worm Reduction Unit 50:1
- KERB EXTRUDETION : Fabricated Ram Cast swing components Hi-tensile shafting
- FRAME AND BODY : Fabricated main frame with removable side and top cover for ease of serving
- MOULDS : Bolt on moulds to customer specification include finishing tools and joint cutter
- PART AVAILABILITY : All parts and components have been selected to ensure world wide parts availability from local sources
- SHIPPING DETAILS : a. Length -2720mm, b. Height -800mm, c. Width -920mm, d. Weight -900 kgs
(We reserve the right to change this specification without notice.)



BESARAM HARDWARE & MACHINERY SDN. BHD. (Co. No. 66512-V)

HQ / FACTORY : Lot No. 1, Jalan 18/62, Kawasan Perusahaan Seri Kembangan, 43300 Seri Kembangan, Selangor, West Malaysia

TEL : +603-8948 3933 (Hunting Line)

FAX : +603-8948 0019

WEBSITE : www.besaram.com.my

Email : besaram@streamyx.com bhmsb@tm.net.my contactus@besaram.com.my nixon@besaram.com.my (Marketing)